

GENERAL INDEX

2

MANUAL RESETTING

5

SELF RESETTING



FOR MORE INFORMATION

www.safe-t-products.com.au



PRE COLLISION DETECTION DEVICE MANUAL RESET

**UV STABLE, IMPACT MODIFIED,
FLAME RETARDANT, PC/PBT ENCLOSURE.**

The Collide-Safe can be used as an over height device for vehicles, trains or used on a stacker/ reclaimer so the operator is alerted to a pre-collision of the structure. The Collide-Safe comes with different Socket Assemblies for different applications.



**Tested to IP66/67
CE Conformity**

The Collide-Safe Pull Cord Device has been tested to the requirements of IEC 60947-5-5 and AS4024 series. Tripping occurs under the following conditions:

- | | |
|-------------------------------------|--------------------------------|
| (a) The trip cord is removed | (c) The trip cord is activated |
| (b) The trip cord is over-tensioned | (d) Manual trip via reset dial |

If tripping has occurred, reset manually via the external reset dial. Reset is only possible when trip cord is attached and correctly tensioned.

FEATURES

- » Quick and simple initial setup and adjustment; all Set Point adjustments are done from the outside of the enclosure
- » UV stable, impact modified, flame retardant, PC/PBT enclosure
- » Simple design ensures low maintenance
- » Stainless steel internal compression type spring
- » 316 stainless steel pull rod
- » Pull rods have spring loaded external dust protecting boots so the pull rod is always covered for extra seal protection and pull rods are not exposed to contaminants
- » Double lip oil seal on pull rod and reset operator for secure dust and weather protection to IP 66/67
- » Increased functional safety through non-metallic pull rod bushing; no electrolysis issues between the safety mechanism (pull rod) and bushing
- » Positive drive action from cams through to switching contacts provides mechanical forcing of the trip contacts
- » IP 66/67 S.P.D.T Change-over Safety Micro Switches with Direct Opening Action (IEC 60947-5-1 Annex K) in contact element form C tested and passed to IEC 60947-5-1
- » Cam design compensates for pull cord expansion/contraction up to 15mm either side of the set point. Eliminates nuisance tripping due to vibration

FOR MORE INFORMATION

www.safe-t-products.com.au



VARIATIONS

- » Socket assembly with two Sockets, ie. with remote end socket.

INSTALLATIONS

- One device mounted for every 50M of pull cord
- » **Remote End;** A matched compensation spring (P/N PS-60) must be fitted to the remote end attachment to allow tripping in both directions. This setup will comply with safety critical functions AS/NZS 4024.3610 -2015 section 2.10.5 Emergency Stop and ISO 13850 Emergency Stop Function - Principles For Design.
 - » Tension the cord so the Pull Rod is extended out to the "Set Position", which is 100mm between the body of the device to the face of the socket attachment plug. No internal access needed to adjust the set point.

See installation instruction

STANDARDS COMPLIANCE

AS/NZS 4024 Series AS/NZS IEC 60947.5.1:2015 AS/NZS IEC 60947.5.5:2015

IEC 60947.5.1:2016 RLV IEC 60947-5-5:1997+AMD1:2005+AMD2:2016 CSV

WHS (Mines) Regulations 2022 part 5.1 division 2, 191

ENCLOSURE SPECIFICATIONS

- » Impact modified PC/PBT - Non Corrosive Material.
- » UV Stabilised. (See RTP 2099 Spec Sheet)
- » Flame retarded ASTM.UL94.V-0 (1.5mm)
- » Resists splash and spillage of most hydrocarbon solvents, mild acids and strong alkali. (See RTP 2099 Spec Sheet)

DIMENSIONS

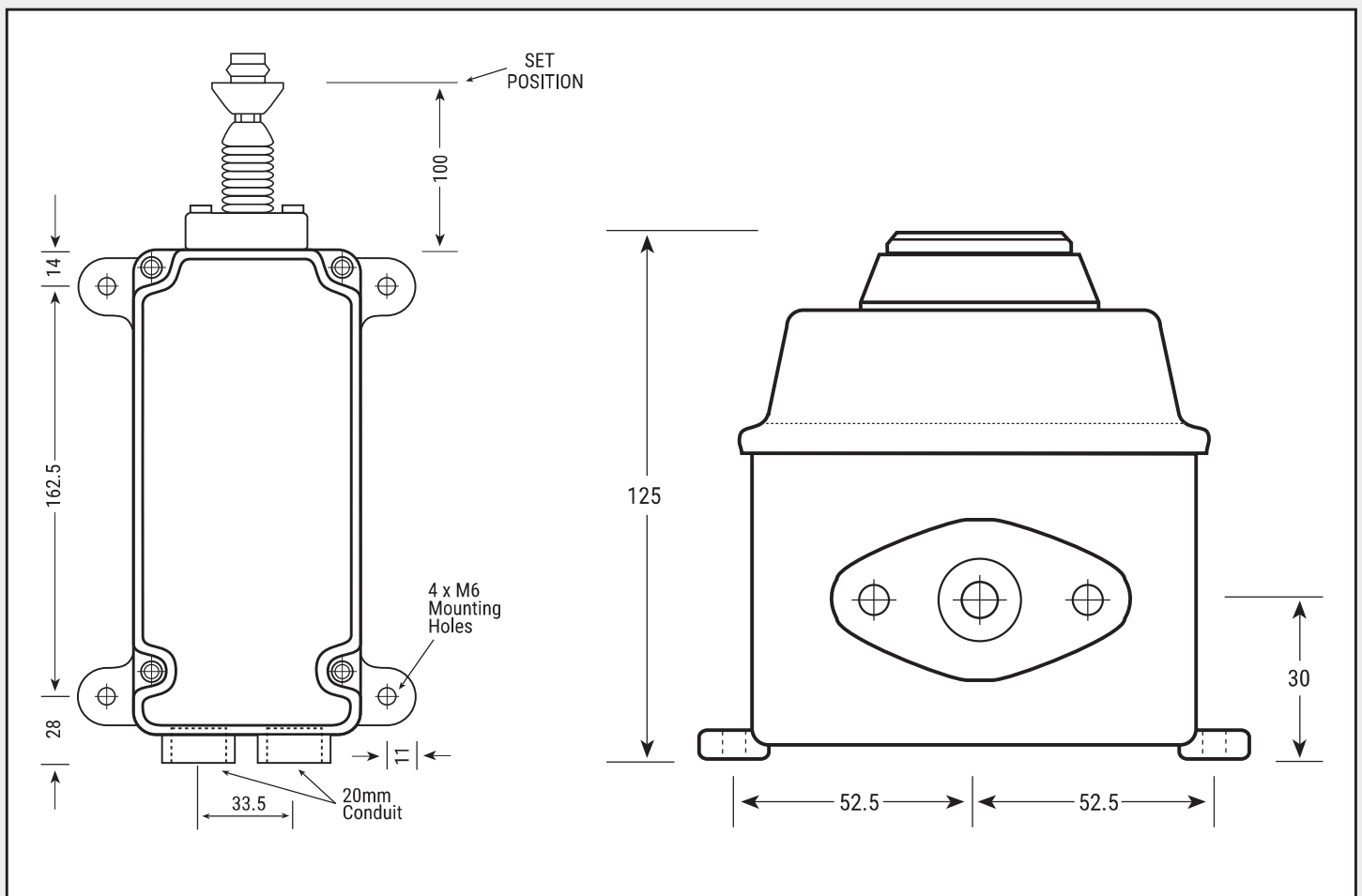

ELECTRICAL SPECIFICATIONS

| Device No. | Type | Voltage | Current | Mechanical Endurance | Operating Temp. |
|------------|--|---------|---------|-----------------------------|-----------------|
| CS-P | S.P.D.T Change-over Safety Micro Switch with Direct Opening Action | 250v | 6A | 1.5 million Operating Cycle | -25°C to 85°C |
| CS-P-2 | | | | | |
| CS-P-3 | | | | | |

ORDERING DETAILS

| COLLIDE-SAFE DEVICE | PART NUMBER |
|---|-------------|
| With 1 S.P.D.T Safety Micro Switches with Direct Opening Action and 10m Pull Cord Kit | CS-P |
| With 2 S.P.D.T Safety Micro Switches with Direct Opening Action and 10m Pull Cord Kit | CS-P-2 |
| With 3 S.P.D.T Safety Micro Switches with Direct Opening Action and 10m Pull Cord Kit | CS-P-3 |
| External Indicator Flag | PS-F |

PRE COLLISION DETECTION DEVICE SELF RESETTING

UV STABLE, IMPACT MODIFIED, FLAME RETARDANT,
PC/PBT ENCLOSURE.



Tested to IP66/67
CE Conformity

The Collide-Safe Device has been tested to the requirements of IEC 60947-5-5 and AS4024 series. Tripping occurs under the following conditions:

- | | |
|-------------------------------------|--------------------------------|
| (a) The trip cord is removed | (c) The trip cord is activated |
| (b) The trip cord is over-tensioned | (d) Automatic resetting |

If tripping has occurred, reset manually via the external reset dial. Reset is only possible when trip cord is attached and correctly tensioned.

FEATURES

- » Quick and simple initial setup and adjustment; all Set Point adjustments are done from the outside of the enclosure
- » UV stable, impact modified, flame retardant, PC/PBT enclosure
- » Simple design ensures low maintenance
- » Stainless steel internal compression type spring
- » 316 stainless steel pull rod
- » Pull rods have spring loaded external dust protecting boots so the pull rod is always covered for extra seal protection and pull rods are not exposed to contaminants
- » Double lip oil seal on pull rod and reset operator for secure dust and weather protection to IP 66/67
- » Increased functional safety through non-metallic pull rod bushing; no electrolysis issues between the safety mechanism (pull rod) and bushing
- » Positive drive action from cams through to switching contacts provides mechanical forcing of the trip contacts
- » IP 66/67 S.P.D.T Change-over Safety Micro Switches with Direct Opening Action (IEC 60947-5-1 Annex K) in contact element form C tested and passed to IEC 60947-5-1
- » Cam design compensates for pull cord expansion/contraction up to 15mm either side of the set point. Eliminates nuisance tripping due to vibration



FOR MORE INFORMATION

www.safe-t-products.com.au



VARIATIONS

- » Max three S.P.D.T Positive Break or Snap Action micro Switches.
- » Socket assembly with two Sockets.

DEVICE SETTINGS

Tension the pull cord so the Pull Rod is extended out to the "Set Position", which is 100mm between the body of the device to the face of the socket attachment plug.

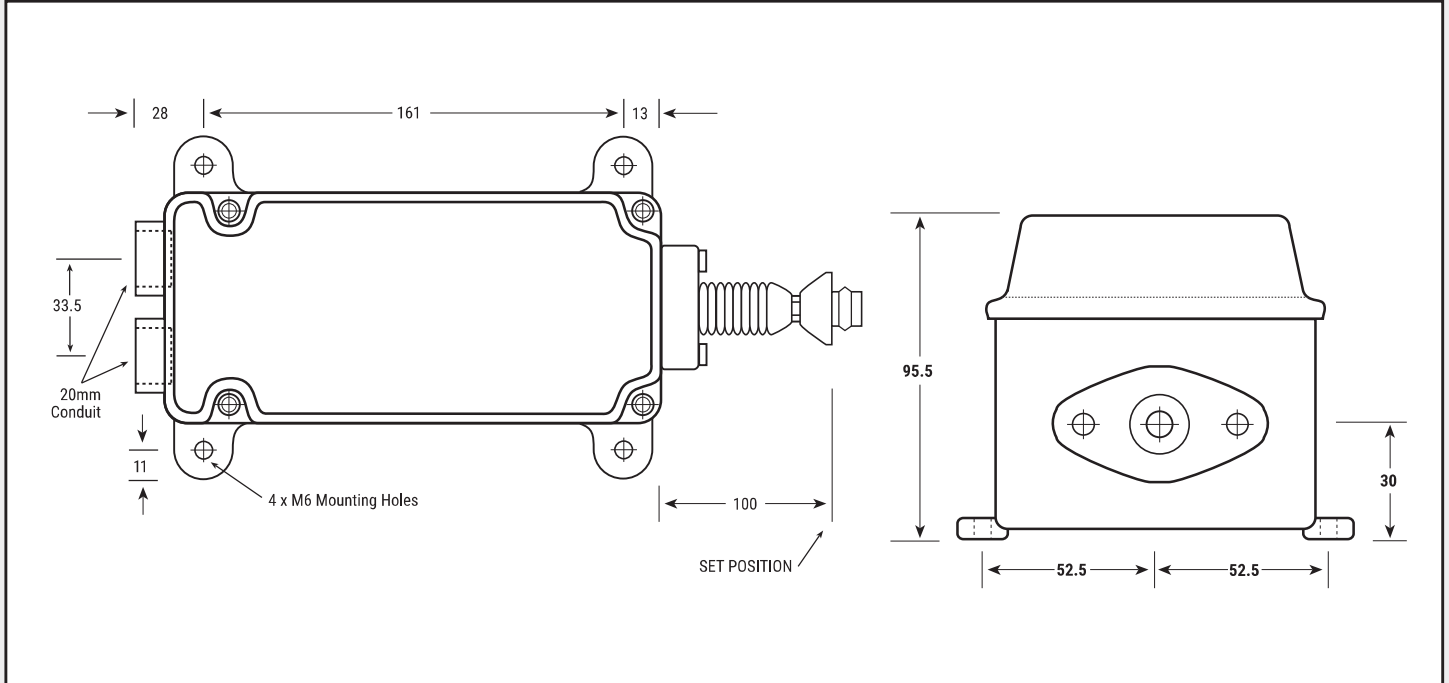

ELECTRICAL SPECIFICATIONS

| Device No. | Type | Voltage | Current | Mechanical Endurance | Operating Temp. |
|------------|--|---------|---------|-----------------------------|-----------------|
| CS-P-SR | S.P.D.T Change-over Safety Micro Switch with Direct Opening Action | 250v | 6A | 1.5 million Operating Cycle | -25°C to 85°C |
| CS-P-SR-2 | | | | | |
| CS-P-SR-3 | | | | | |

ENCLOSURE SPECIFICATIONS

- » High Impact PC/PBT non Corrosive Material.
- » UV Stable (See RTP 2099 Spec Sheet).
- » Flame retardant ASTM:UL94-V0 (1.5mm) Resist splash and spillage of most Hydrocarbon Solvents, mild Acids and strong Alkali (See RTP 2099 Spec Sheet).

ORDERING DETAILS

| STANDARD DEVICE | PART NUMBER |
|---|------------------|
| Standard Device with 1 S.P.D.T Safety Micro Switches with Direct Opening Action and 10m Pull Cord Kit | CS-P-SR |
| Standard Device with 2 S.P.D.T Safety Micro Switches with Direct Opening Action and 10m Pull Cord Kit | CS-P-SR-2 |
| Standard Device with 3 S.P.D.T Safety Micro Switches with Direct Opening Action and 10m Pull Cord Kit | CS-P-SR-3 |
| External Signal Flag | PS-F |
| Pull Cord lengths available in 5m increments example: CS-P-SR-2-25 | add -15, -20 etc |
| 10m Pull Cord kits with Socket, 3 Rope Grips, 5mm Stainless Steel eye/eye Turnbuckle, M6 x 40 Stainless Steel Eye Bolt and PS-60 Compensation Spring. | |